



- Unità di guida per cilindri ISO 15552 e microcilindri ISO 6432
Guiding units for cylinders ISO 15552 and minicylinders ISO 6432
 - Versioni disponibili:
 - tipo "U" con bronzine (cod. **UB...**) - per cilindri da alesaggio 12 a 63
 - tipo "H" con bronzine (cod. **HB...**) - per cilindri da alesaggio 12 a 63
 - tipo "H" con cuscinetti a rotolamento (cod. **HS...**) - per cilindri da alesaggio 12 a 63
- Available versions:*
- type "U" with sintered bronze rod guide (code **UB...**) - cylinder bores from 12 to 63
 - type "H" with sintered bronze rod guide (code **HB...**) - cylinder bores from 12 to 63
 - type "H" with linear ball bearings (code **HS...**) - cylinder bores from 12 to 63
- Tipo "U" con bronzine: movimentazione con carichi medi e basse velocità
Type "U" with sintered bronze rod guide: movements with medium loads and low speeds
 - Tipo "H" con bronzine: movimentazione con carichi pesanti e basse velocità
Type "H" with sintered bronze rod guide: movements with heavy loads and low speeds
 - Tipo "H" con cuscinetti a rotolamento: movimentazione con carichi medi e alte velocità
Type "H" with linear ball bearings: movements with medium loads and high speeds

Materiali

Corpo: alluminio anodizzato

Steli: C40 cromato

Materials

Body: aluminium (anodize treatment)

Rods: C40 (chromium plated)

chiave di codifica

key to codes

H B 0 6 3 C 1 5 0



Tipo [type]

H tipo "H" [type "H"]

U tipo "U" [type "U"]

Guida stelo [rod guide]

B bronzine [sintered bronze]

S cuscinetti a rotolamento - solo tipo H
[linear ball bearings - only type H]

alesaggi e corse disponibili

available bores and strokes

alesaggio corsa stroke	12* 16	20	25	32	40	50	63
50	X	X	X	X	X	X	X
100	X	X	X	X	X	X	X
150				X	X	X	X
160	X	X	X				
200	X	X	X	X	X	X	X
250	X	X	X	X	X	X	X
300				X	X	X	X
400				X	X	X	X
500				X	X	X	X

* L'unità di guida per l'alesaggio 12 si utilizza anche per l'alesaggio 16. Il codice rimane quello dell'alesaggio 12.

* The guiding unit for bore 12 is used also for bore 16, with the same code.

Carico ammissibile / Permissible loads

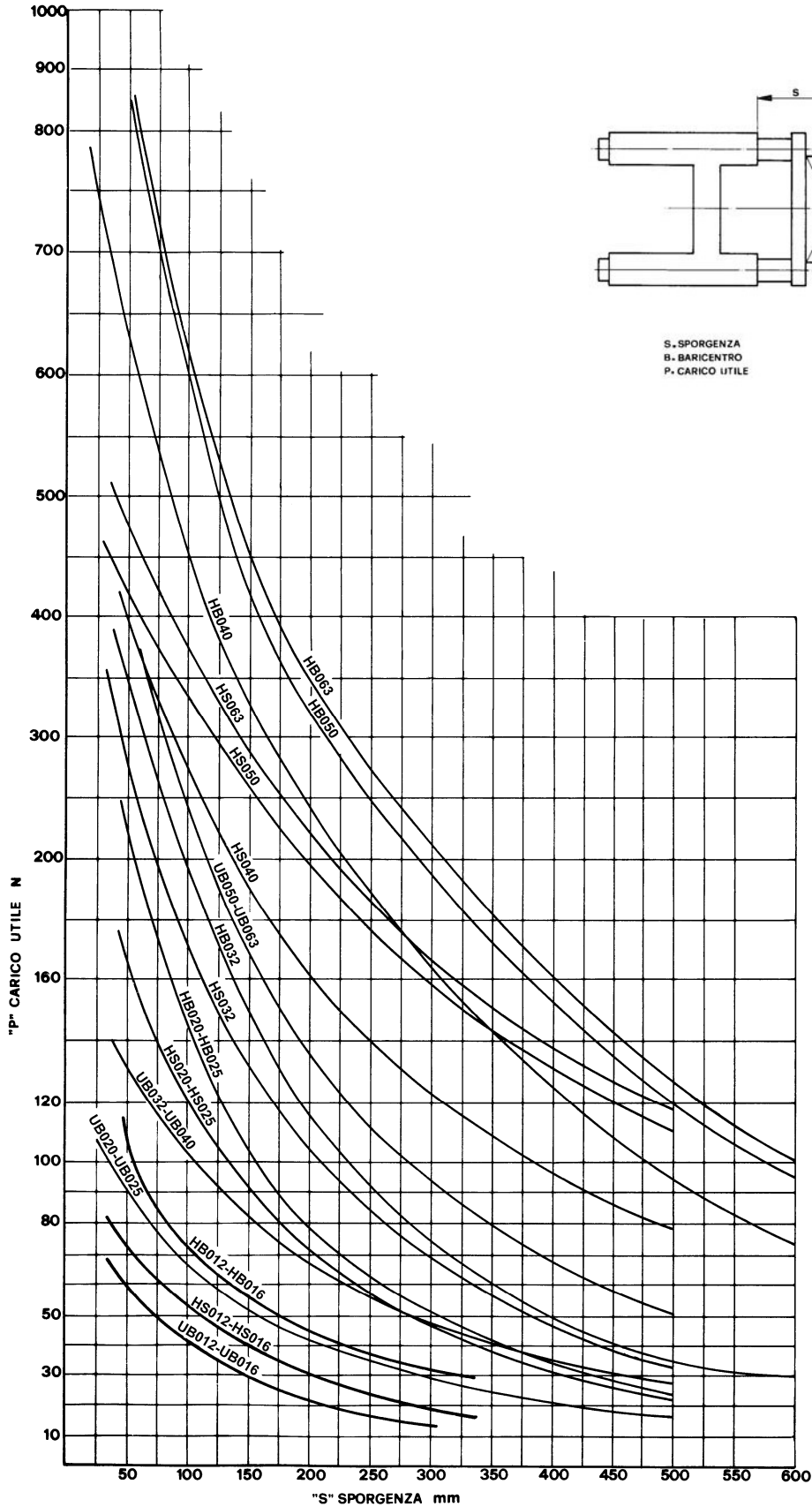

tipo "U" per microcilindri ISO 6432

type "U" for minicylinders ISO 6432

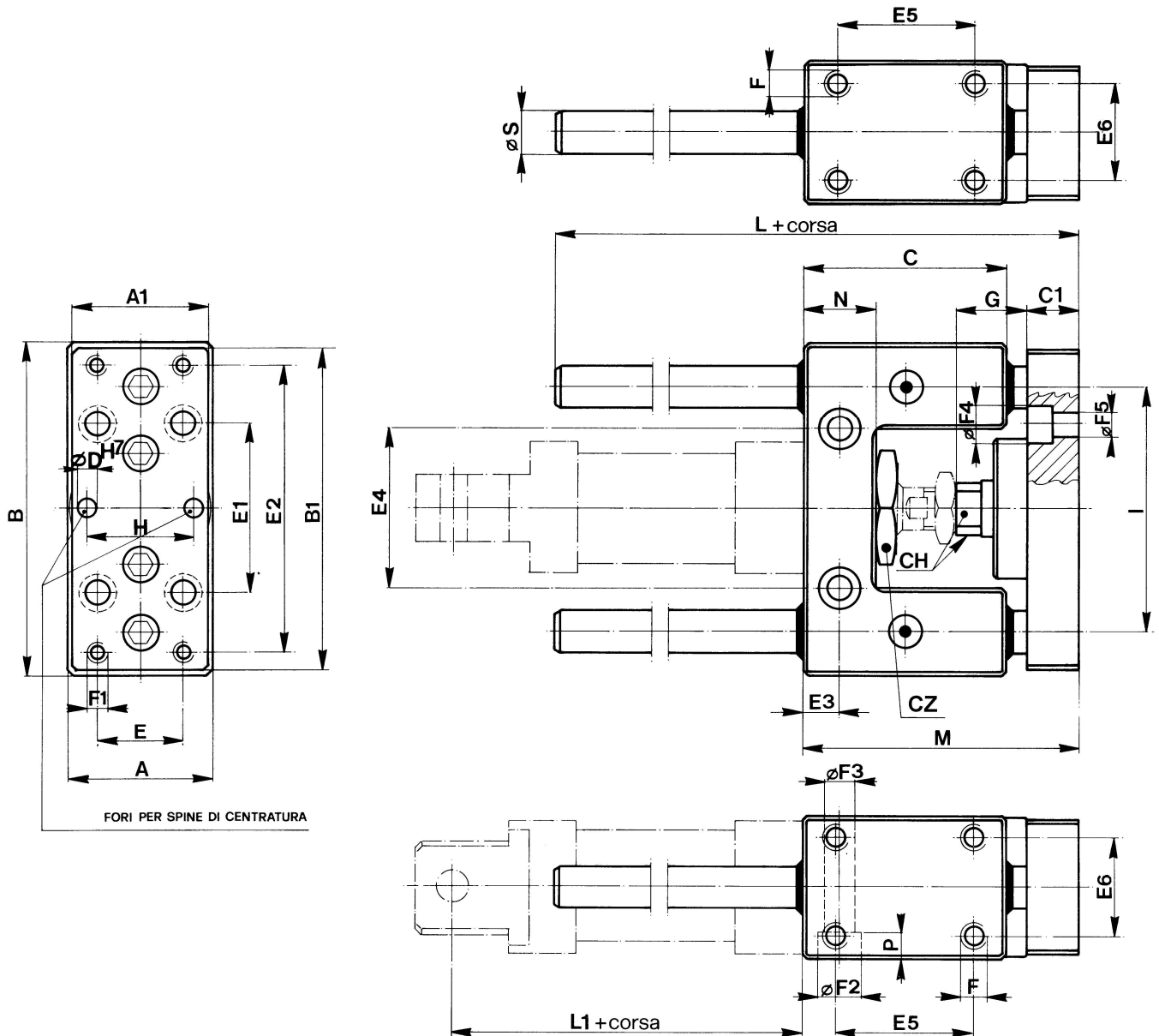

\varnothing CIL	A	A1	B	B1	C	C1	CH	CZ	D	E	E1	E2	E3	E4	E5	E6	F	F1	F2	F3	F4	F5	G	H	I	L	L1	M	N	P	S
12 16	30	27	65	63	38	10	8	19	4	15	32	54	6.5	24	25	22	M4	M4	8.5	5.1	7.5	4.5	12	15	46	70	53	13	5.5	8	
																											60				
20	34	32	79	76	48	12	12	27	6	20	40	68	8.5	38	32.5	23	M6	M5	10.5	6.5	9	5.5	22	20	58	83	71	65	17	6.5	10
25	34	32	79	76	48	12	12	27	6	20	40	68	8.5	38	32.5	23	M6	M5	10.5	6.5	9	5.5	17	20	58	83	76	65	17	6.5	10

tipo "U" per cilindri ISO 6431

type "U" for cylinders ISO 6431

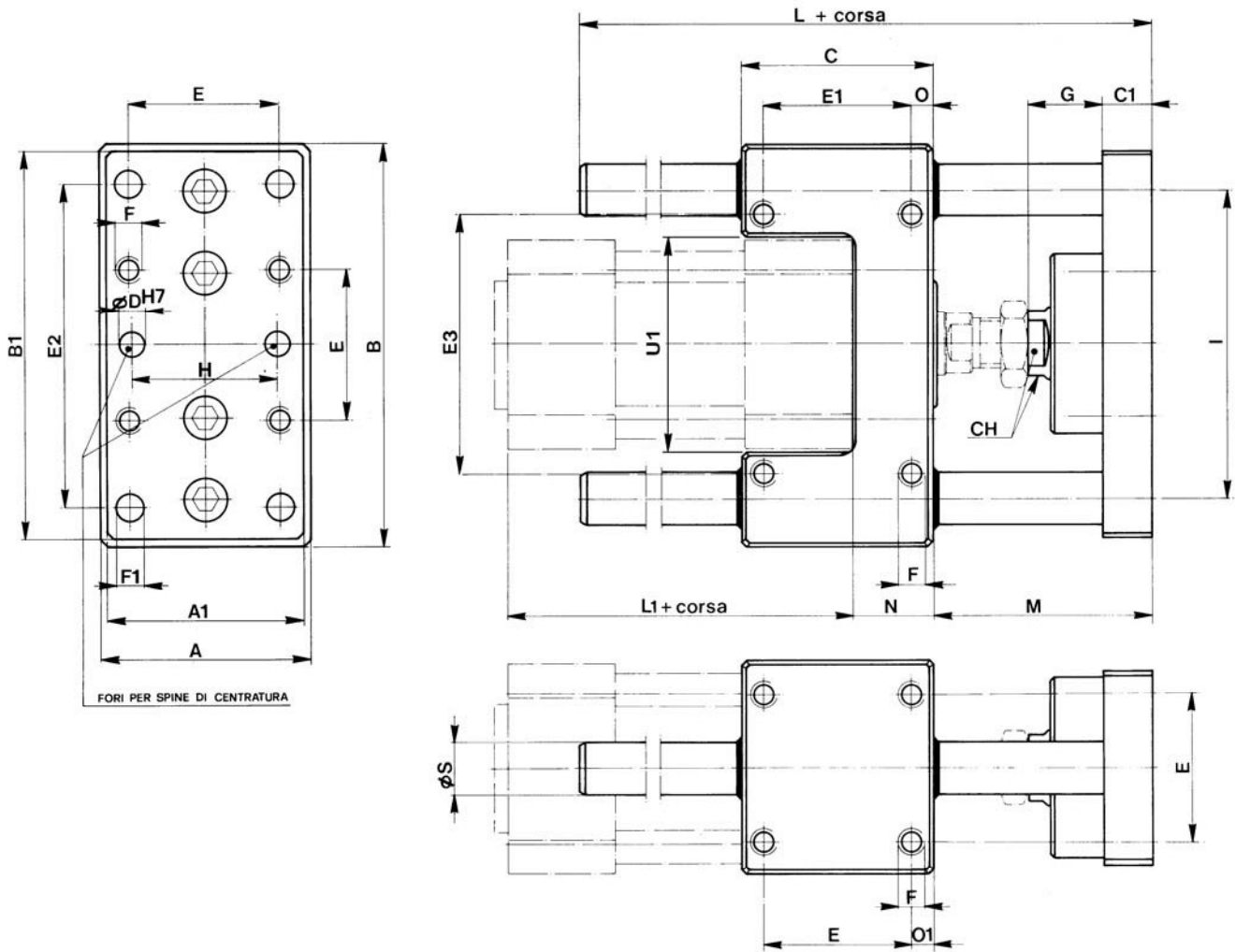

6

\varnothing CIL	A	A1	B	B1	C	C1	D	E	E1	E2	E3	F	F1	G	H	I	L	L1	M	N	O	O1	S	CH	U1
32	48	45	100	90	48	12	6	32.5	32.5	78	58	M6	6.5	20	31	74	106	94	54	17	7.8	7.8	12	13	48
40	56	50	106	105	58	12	6	38	38	84	64	M6	6.5	22	36	80	117	105	55	21	10	10	12	15	54
50	66	60	125	124	59	15	6	46.5	46.5	100	80	M8	9	23	45	96	129	106	68	25	6.3	6.3	16	21	67
63	76	70	132	125	76	15	6	56.5	56.5	105	95	M8	9	23	45	104	146	121	68	25	9.8	9.8	16	21	76

tipo "H" per microcilindri ISO 6432

type "H" for minicylinders ISO 6432

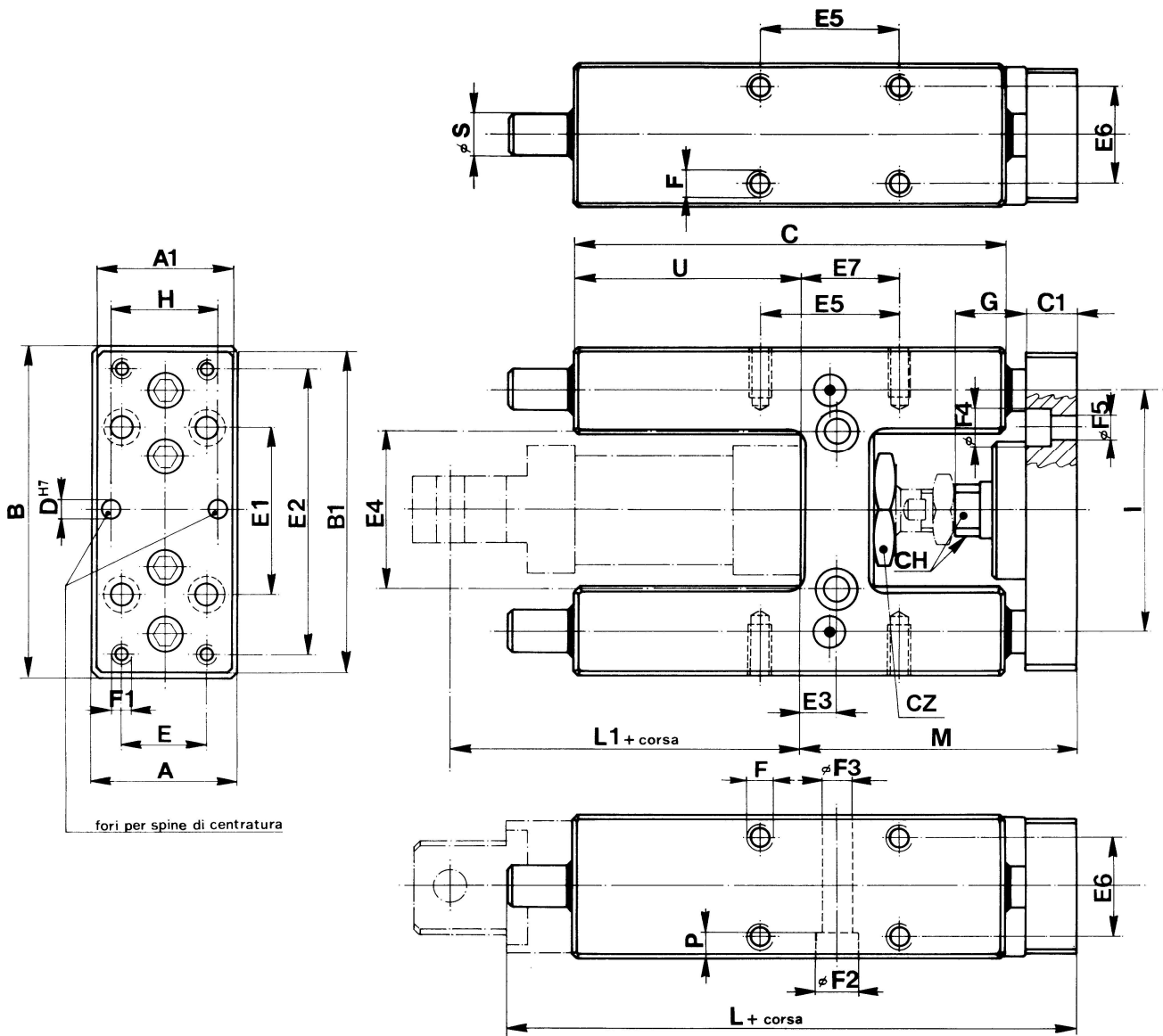

∅ CIL	A	A1	B	B1	C	C1	CH	CZ	D	E	E1	E2	E3	E4	E5	E6	E7	F	F1	F2	F3	F4	F5	G	H	I	L	L1	M	P	S	U
12 16	30	27	65	63	75	10	8	19	4	15	32	54	6.5	24	32.5	22	11	M4	M4	8.5	5.1	7.5	4.5	12	15	46	130	53	51	5.5	8	37
																												60				
20	34	32	79	76	108	12	12	27	6	20	40	68	8.5	38	32.5	23	15	M6	M5	10.5	6.5	9	5.5	22	20	58	159	71	65	6.5	10	58
25	34	32	79	76	108	12	12	27	6	20	40	68	8.5	38	32.5	23	15	M6	M5	10.5	6.5	9	5.5	17	20	58	159	76	65	6.5	10	58

tipo "H" per cilindri ISO 6431

type "H" for cylinders ISO 6431

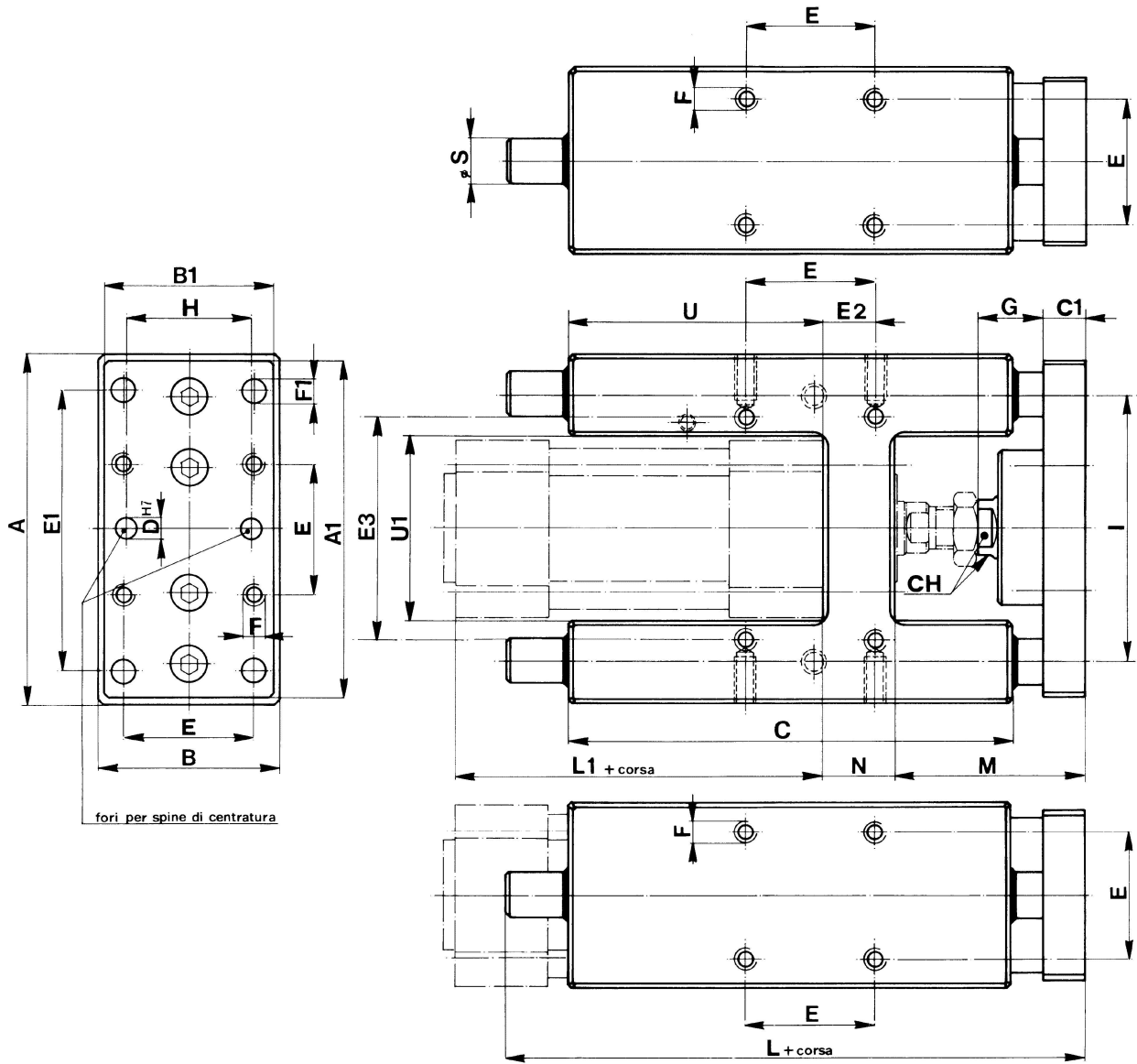

∅ CIL	A	A1	B	B1	C	C1	CH	D	E	E1	E2	E3	F	F1	G	H	I	L	L1	M	N	S	U	U1
32	97	90	50	45	125	12	13	6	32.5	78	4.3	61	M6	6.5	20	31	74	177	94	54	17	12	76	50.5
40	115	105	58	50	136	12	15	6	38	84	11	69	M6	6.5	22	36	87	192	105	55	21	16	81	58.5
50	137	124	70	60	144	15	21	6	46.5	100	18.5	85	M8	9	23	45	104	237	106	68	26	20	79	70.5
63	152	145	85	70	176	15	21	6	56.5	105	15.3	100	M8	9	23	45	119	237	121	68	26	20	111	85.5

KIT UNITÀ DI GUIDA

kit for guiding units

Il kit comprende tutti i pezzi necessari per il montaggio escluso gli steli, per la cui realizzazione il disegno si trova sul sito internet:
<http://www.azpneumatica.srl/azweb/ita/kitguid.htm>

The kit includes all the necessary pieces. Rods are not included. The drawing for rod machining is available in internet at the following address:
<http://www.azpneumatica.srl/azweb/ita/kitguid.htm>

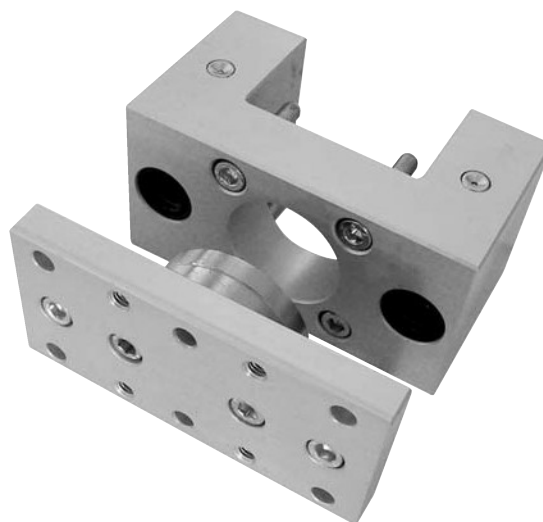

Tipo "U" con bronzine

type "U" with sintered bronze rod guide

per alesaggio for bore	sigla part number	codice code
12-16	KUB012-016	27.271.0
20	KUB020	27.272.0
25	KUB025	27.273.0
32	KUB032	27.274.0
40	KUB040	27.275.0
50	KUB050	27.278.0
63	KUB063	27.279.0

Tipo "H" con bronzine

type "H" with sintered bronze rod guide

per alesaggio for bore	sigla part number	codice code
12-16	KHB012-016	27.259.0
20	KHB020	27.250.0
25	KHB025	27.251.0
32	KHB032	27.252.0
40	KHB040	27.253.0
50	KHB050	27.254.0
63	KHB063	27.255.0

Tipo "H" con cuscinetti a rotolamento

type "H" with linear ball bearings

per alesaggio for bore	sigla part number	codice code
12-16	KHS012-016	27.260.0
20	KHS020	27.261.0
25	KHS025	27.268.0
32	KHS032	27.262.0
40	KHS040	27.263.0
50	KHS050	27.264.0
63	KHS063	27.265.0



- Unità di guida per cilindri ISO 15552 e microcilindri ISO 6432
Guiding units for cylinders ISO 15552 and minicylinders ISO 6432
- Versioni disponibili: tipo "U" con bronzine (cod. **SUB...**) - per cilindri da alesaggio 12 a 100
tipo "H" con bronzine (cod. **SHB...**) - per cilindri da alesaggio 16 a 100
*Available versions: type "U" with sintered bronze rod guide (code **SUB...**) - cylinder bores from 12 to 100
type "H" with sintered bronze rod guide (code **SHB...**) - cylinder bores from 16 to 100*
- Tipo "U" con bronzine: movimentazione con carichi medi e basse velocità
Type "U" with sintered bronze rod guide: movements with medium loads and low speeds
- Tipo "H" con bronzine: movimentazione con carichi pesanti e basse velocità
Type "H" with sintered bronze rod guide: movements with heavy loads and low speeds

Materiali

Corpo: alluminio anodizzato

Steli: C40 cromato

Materials

Body: aluminium (anodize treatment)

Rods: C40 (chromium plated)

chiave di codifica

key to codes

S U B 0 6 3 C 1 5 0 C

tipo
type
guida stelo
rod guide

nipplo
coupling

corsa
stroke

alesaggio cilindro
cylinder bore

Tipo [type]

H tipo "H" [type "H"]

U tipo "U" [type "U"]

Guida stelo [rod guide]

B bronzine [sintered bronze]

Nipplo - solo per tipo H a partire da alesaggio 20

[coupling - only for type H from bore 20]

C nipplo corto [short coupling]

L nipplo lungo [long coupling]

alesaggi e corse disponibili

available bores and strokes

alesaggio corsa bore stroke	12 16	20	25	32	40	50	63	80	100
50	X	X	X	X	X	X	X	X	X
100	X	X	X	X	X	X	X	X	X
150				X	X	X	X	X	X
160	X	X	X						
200	X	X	X	X	X	X	X	X	X
250	X	X	X	X	X	X	X	X	X
300				X	X	X	X	X	X
400				X	X	X	X	X	X
500				X	X	X	X	X	X

carico ammissibile
permissible load

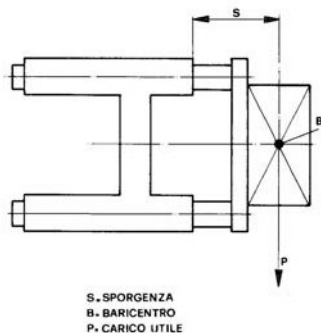

tipo "H"
type "H"

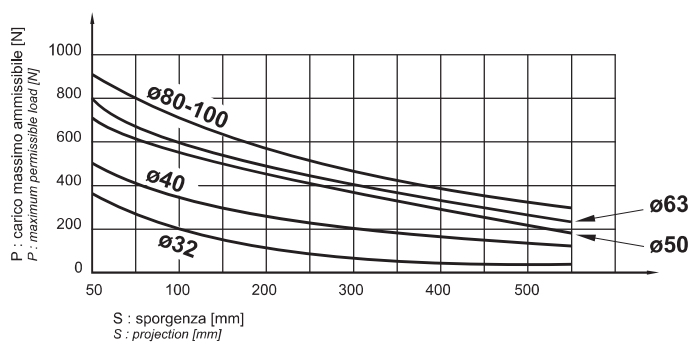
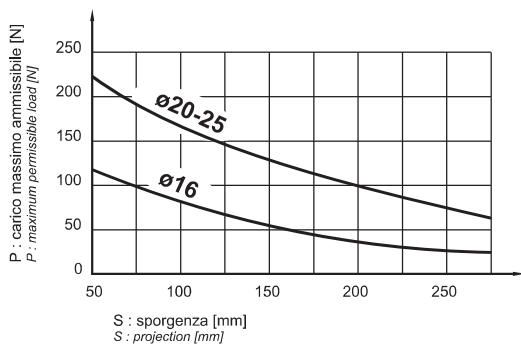

tipo "U"
type "U"

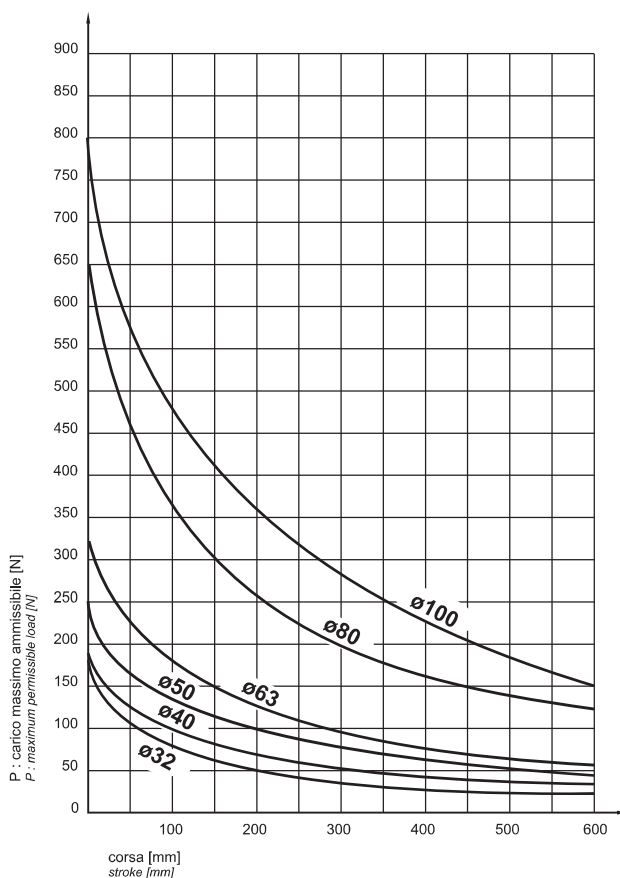

TIPO "U" PER MICROCILINDRI ISO 6432

type "U" for minicylinders ISO 6432

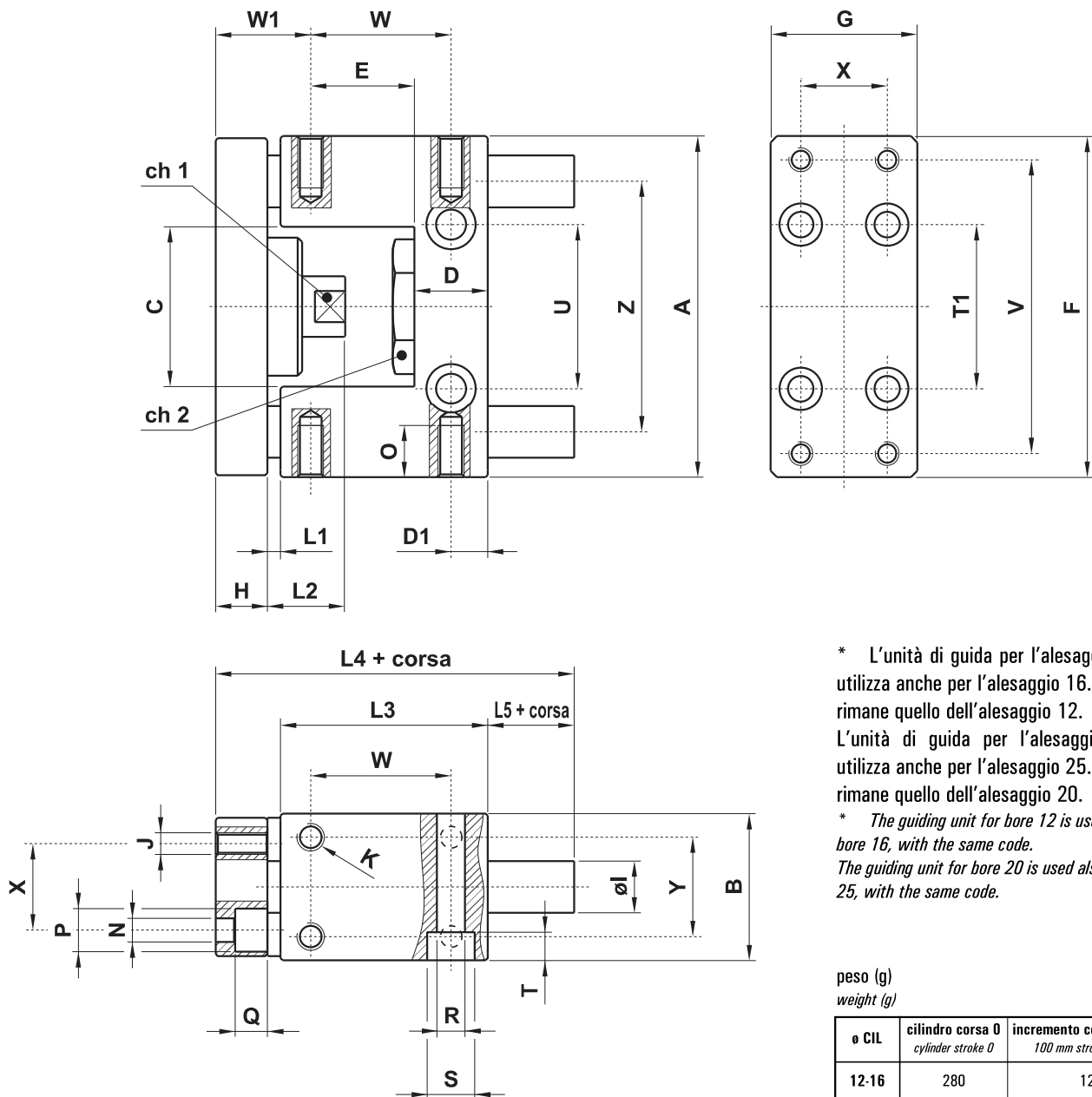
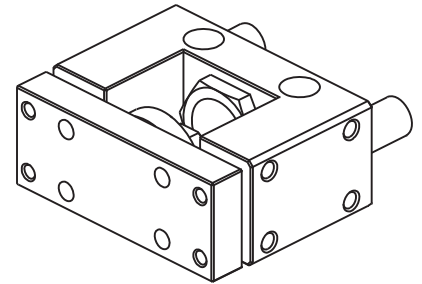

* L'unità di guida per l'alesaggio 12 si utilizza anche per l'alesaggio 16. Il codice rimane quello dell'alesaggio 12.

L'unità di guida per l'alesaggio 20 si utilizza anche per l'alesaggio 25. Il codice rimane quello dell'alesaggio 20.

* The guiding unit for bore 12 is used also for bore 16, with the same code.

The guiding unit for bore 20 is used also for bore 25, with the same code.

peso (g)
weight (g)

ø CIL	cilindro corsa 0 cylinder stroke 0	incremento corsa 100 mm 100 mm stroke increase
12-16	280	123
20-25	490	178

ø CIL*	A	B	C	ch1	ch2	D	D1	E	F	G	H	øl	J	K	L1	L2	L3	L4	L5	N	O	P	Q	R	S	T	T1	U	V	W	W1	X	Y	Z
12-16	69	30	30	8	24	12	6	20	66	29	10	10	M4	M4	3	15	38	66.5	15.5	4.5	6	7.5	4.5	5.5	9	5.5	32	24	58	25	19.5	18	22	49.5
20-25	79	34	37	12	27	17	8.5	24	78	32	12	12	M5	M6	3	18	48	83	20	5.5	9	10	7.5	6.5	11	6.5	38	38	68	33	21.8	20	23	58

TIPO "U" PER CILINDRI ISO 15552

type "U" for cylinders ISO 15552

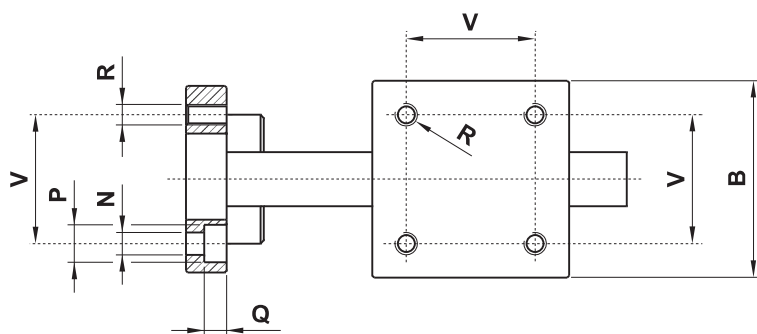
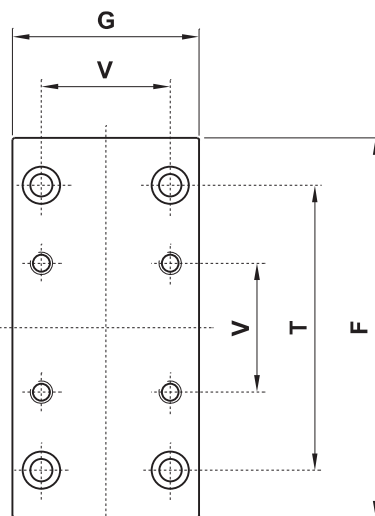
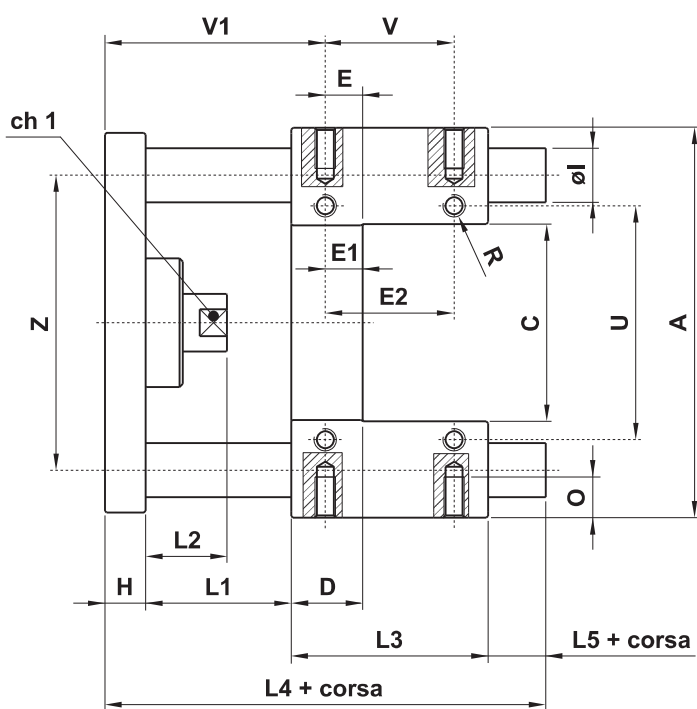
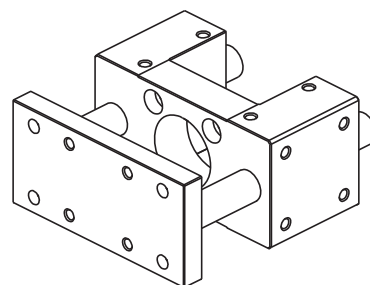

peso (g)
weight (g)

ø CIL	cilindro corsa Ø cylinder stroke Ø	incremento corsa 100 mm 100 mm stroke increase
32	750	178
40	1230	316
50	2150	500
63	2890	500
80	5700	770
100	7950	770

ø CIL	A	B	C	ch	D	E	E1	E2	F	G	H	øl	L1	L2	L3	L4	L5	N	O	P	Q	R	T	U	V	V1	Z
32	97	49	51	15	17	9.25	9.25	32.5	93	45	12	12	42	25	48	102	18	6.6	12	11	6.5	M6	78	61	32.5	61.75	74
40	115	58	58.5	15	21	11	11	38	112	55	12	16	43	25	58	113	17	6.6	12	11	6.5	M6	84	69	38	65	87
50	137	70	70.2	20	25	18.8	18.8	46.5	134	65	15	20	49	29	59	123	20	9	16	15	8.5	M8	100	85	46.5	70.2	104
63	152	85	85.2	20	25	15.3	15.3	56.5	147	80	15	20	49	29	76	140	21	9	16	15	9	M8	105	100	56.5	73.7	119
80	189	105	105.5	26	34	25	14	50	180	100	20	25	53	27	90	163	30	11	20	18	11	M10	130	130	72	82	148
100	213	130	130.5	26	39	28.5	19	70	206	120	20	25	54	27	110	184	30	11	20	18	11	M10	150	150	89	84.5	173

TIPO "H" PER MICROCILINDRI ISO 6432

type "H" for minicylinders ISO 6432

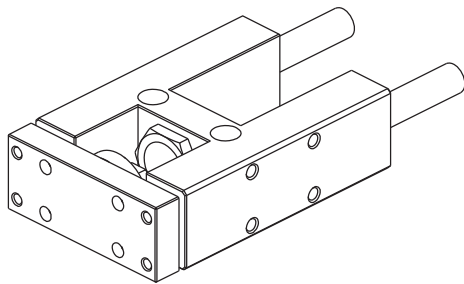
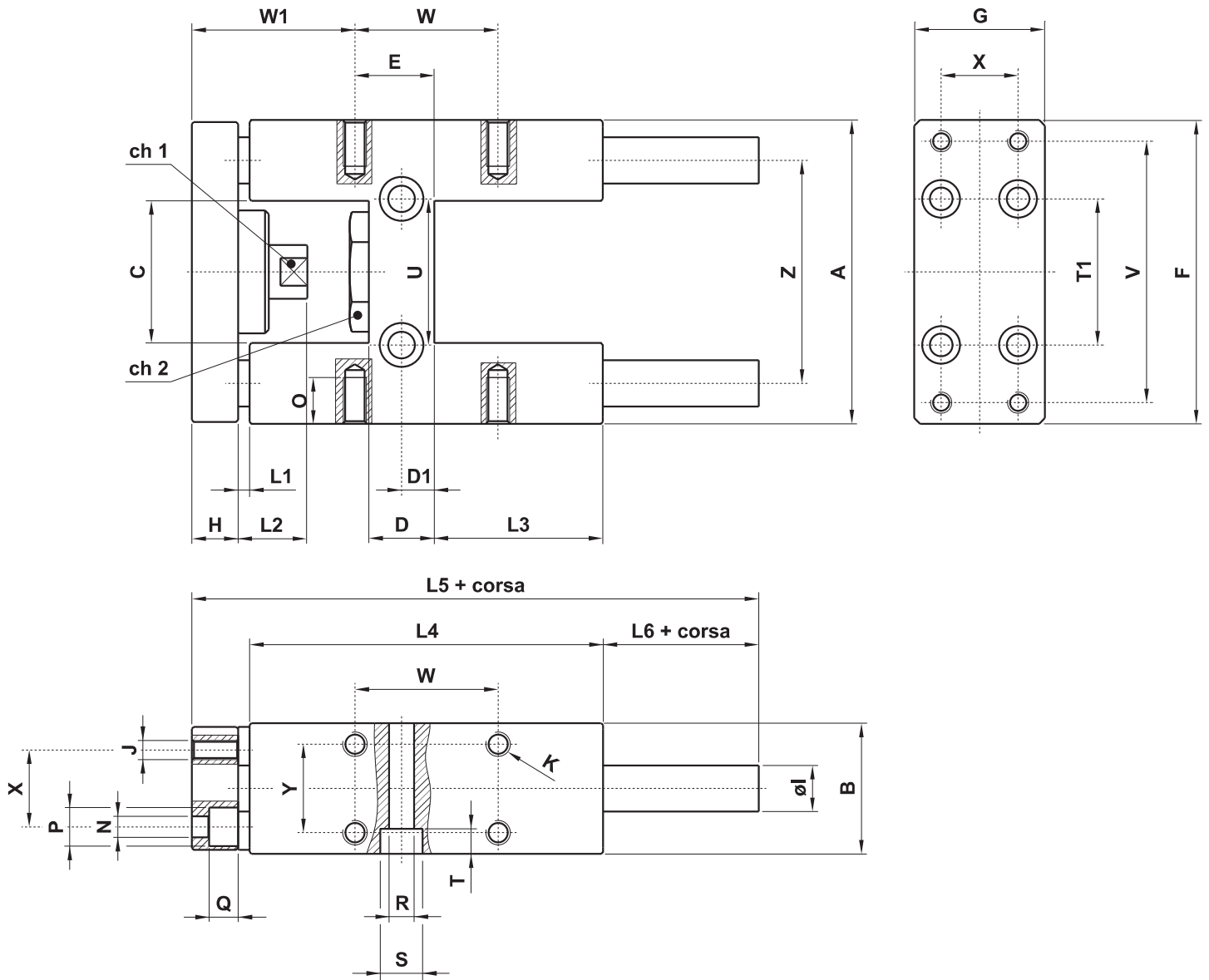

nipplo corto
short coupling

peso (g)
weight (g)

ø CIL	cilindro corsa 0 cylinder stroke 0	incremento corsa 100 mm 100 mm stroke increase
16	400	120
20-25	900	180

nipplo lungo
long coupling

ø CIL	L1	L2	L6
20	25	40	87
25	25	40	91

ø CIL	A	B	C	ch1	ch2	ch3	D	D1	E	F	G	H	øI	J	K	L1	L2	L3	L4	L5	L6	M	N	O	P	Q	R	S	T	T1	U	V	W	W1	X	Y	Z
16	69	30	30	8	10	24	12	6	8	66	29	10	10	M4	M4	25	18	46	68	123.5	73	4	4.5	6	8	4.5	5.5	9	5.5	32	24	58	18	-	18	22	49.5
20	79	34	37	12	13	27	17	8.5	15	78	32	12	12	M5	M6	3	18	58	108	166	43	5	5.5	9	10	7.5	6.5	11	6.5	38	38	68	32.5	50	20	23	58
25	79	34	37	12	17	27	17	8.5	15	78	32	12	12	M5	M6	3	18	58	108	166	43	5	5.5	9	10	7.5	6.5	11	6.5	38	38	68	32.5	50	20	23	58

unità di guida

guiding units



TIPO "H" PER CILINDRI ISO 15552

type "H" for cylinders ISO 15552

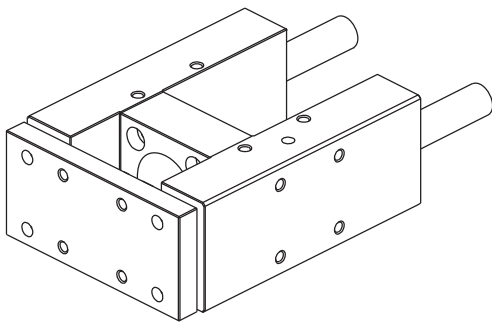
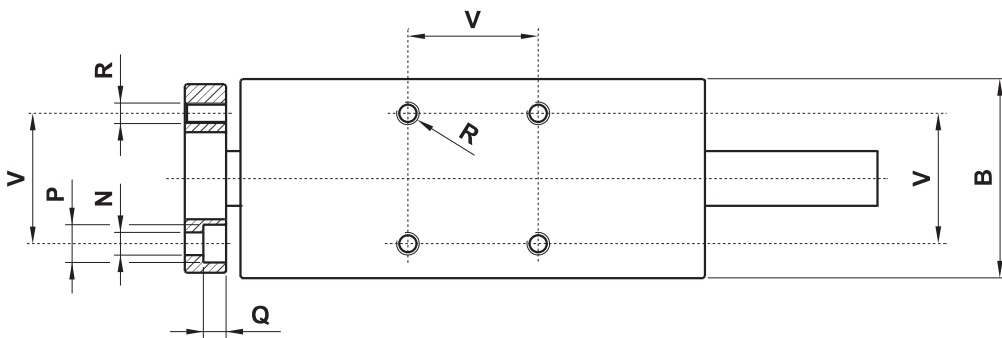
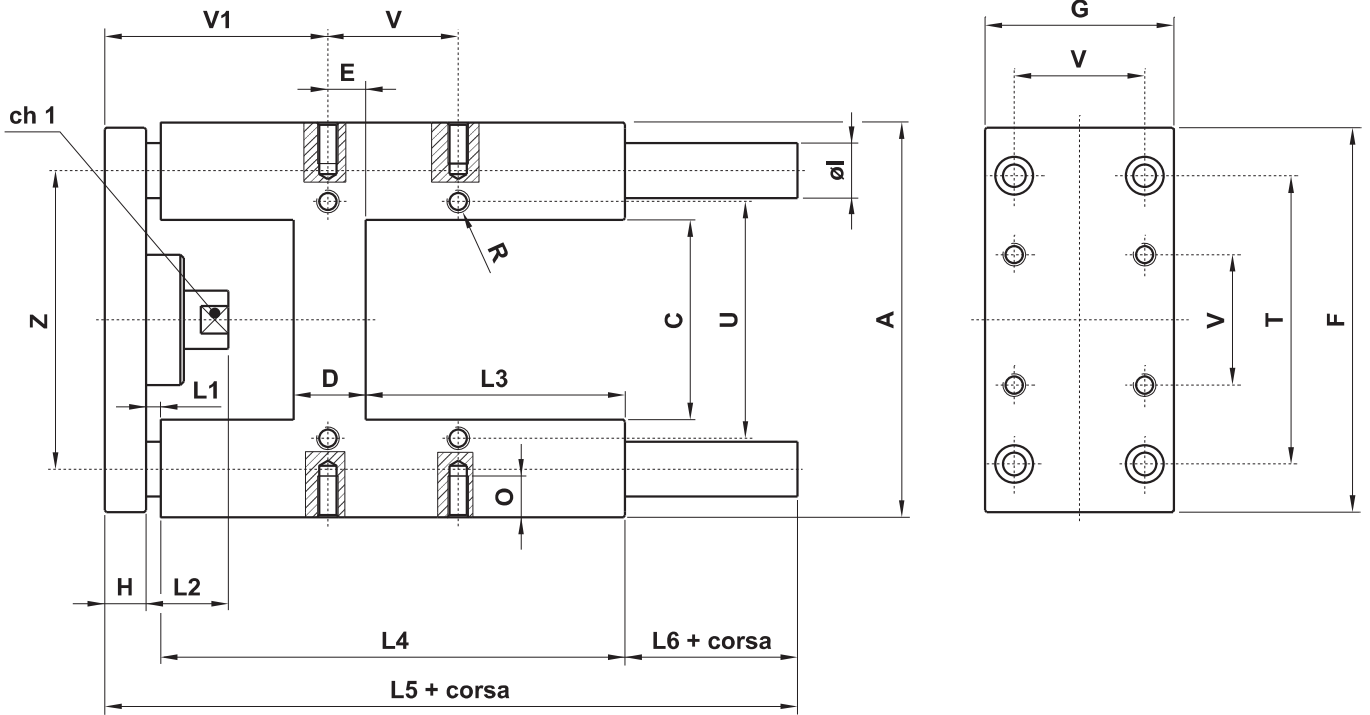

niplo corto
short coupling

peso (g)
weight (g)

ø CIL	cilindro corsa 0 cylinder stroke 0	incremento corsa 100 mm 100 mm stroke increase
32	1300	180
40	2400	320
50	3500	500
63	4600	500
80	8400	770
100	11800	770

niplo lungo
long coupling

ø CIL	L1	L2	L6	V1
32	26	42	24	83.7
40	25	42	30	86
50	25	50	35	91.2
63	25	50	25	96.7
80	25	50	27	104
100	25	50	27	105

ø CIL	A	B	C	ch	D	E	F	G	H	øI	L1	L2	L3	L4	L5	L6	N	O	P	Q	R	T	U	V	V1	Z
32	97	49	51	15	24	4.3	93	45	12	12	3	19	75	125	187	47	6.6	12	11	6.5	M6	78	61	32.5	60.7	74
40	115	58	58.2	15	28	11	112	55	12	16	3	24	80	140	207	52	6.6	12	11	6.5	M6	84	69	38	64	87
50	137	70	70.2	20	34	18.8	134	65	15	20	3	27	78	148	223	57	9	16	15	8.5	M8	100	85	46.5	69.2	104
63	152	85	85.2	20	34	15.3	147	80	15	20	3	27	106	178	243	47	9	16	15	9	M8	105	100	56.5	74.7	119
80	189	105	105.5	26	50	25	180	100	20	25	3	27	111	195	267	49	11	20	18	11	M10	130	130	72	82	148
100	213	130	130.5	26	55	30	206	120	20	25	3	27	128	218	290	49	11	20	18	11	M10	150	150	89	83	173

PIASTRA DI FISSAGGIO UNITÀ DI GUIDA "H"

mounting plate for guiding units type "H"

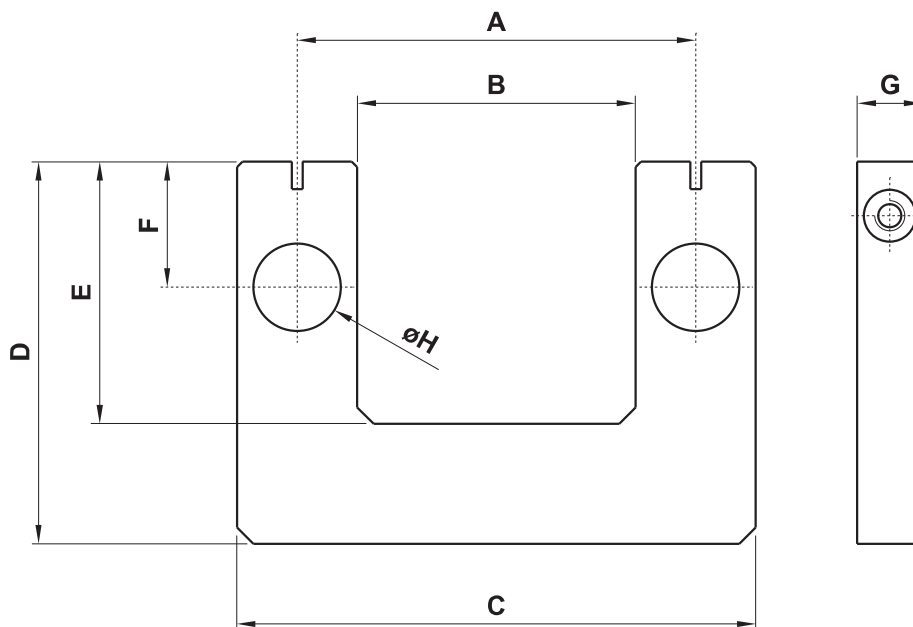

codice code	∅ CIL	A	B	C	D	E	F	G	H
47.410.0	16	49.5	31.5	68	45	33	15.5	12	10
47.411.0	20-25	58	37	78	50	34	15.5	12	12
47.412.0	32	74	51	95	70	48	23	12	12
47.413.0	40	87	58.2	113	80	55	26	12	16
47.414.0	50	104	70.2	134	100	67.5	32.5	15	20
47.415.0	63	119	91	147	120	82	39.5	15	20
47.416.0	80	148	105.5	185	150	101	48.5	20	25
47.417.0	100	173	137	209	165	114	49	20	25

Ogni pezzo è venduto in kit con i particolari necessari al suo assemblaggio.
Each element is sold in kit with all necessary pieces for installation.

KIT UNITÀ DI GUIDA

kit for guiding units

Il kit comprende tutti i pezzi necessari per il montaggio escluso gli steli, per la cui realizzazione il disegno si trova sul sito internet:
<http://www.azpneumatica.srl/azweb/ita/kitguids.htm>

The kit includes all the necessary pieces. Rods are not included. The drawing for rod machining is available in internet at the following address:
<http://www.azpneumatica.srl/azweb/ita/kitguids.htm>

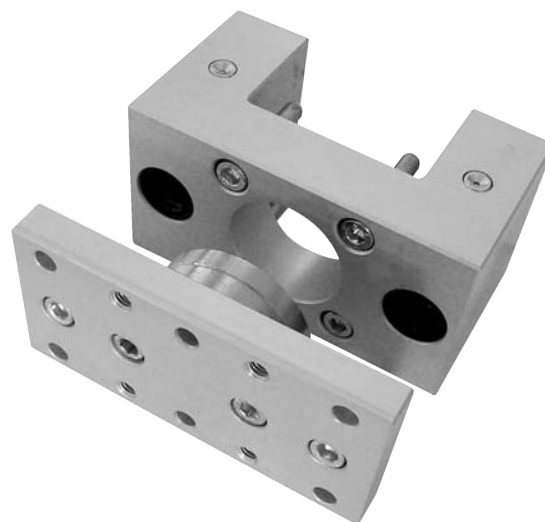

6

Tipo "U" con bronzine

type "U" with sintered bronze rod guide

per alesaggio for bore	sigla part number	codice code
12-16	SKUB012-016	47.271.0
20	SKUB020	47.272.0
25	SKUB025	47.273.0
32	SKUB032	47.274.0
40	SKUB040	47.275.0
50	SKUB050	47.278.0
63	SKUB063	47.279.0
80	SKUB080	47.280.0
100	SKUB100	47.281.0

Tipo "H" con bronzine

type "H" with sintered bronze rod guide

per alesaggio for bore	sigla part number	codice code
12-16	SKHB012-016	47.259.0
20	SKHB020	47.250.0
25	SKHB025	47.251.0
32	SKHB032	47.252.0
40	SKHB040	47.253.0
50	SKHB050	47.254.0
63	SKHB063	47.255.0
80	SKHB080	47.256.0
100	SKHB100	47.257.0